

NOTICE OF REVISION (NOR)		1. DATE (YYMMDD) 02-12-17	Form Approved OMB No. 0704-0188
THIS REVISION DESCRIBED BELOW HAS BEEN AUTHORIZED FOR THE DOCUMENT LISTED.			
Public reporting burden for this collection is estimated to average 2 hours per response, including the time for reviewing instructions, searching existing data sources, gathering and maintaining the data needed, and completing and reviewing the collection of information. Send comments regarding this burden estimate or any other aspect of this collection of information, including suggestions for reducing this burden, to Department of Defense, Washington Headquarters Services, Directorate for Information Operations and Reports, 1215 Jefferson Davis Highway, Suite 1204, Arlington, VA 22202-4302, and to the Office of Management and Budget, Paperwork Reduction Project (0704-0188), Washington, DC 20503. PLEASE DO NOT RETURN YOUR COMPLETED FORM TO EITHER OF THESE ADDRESSED. RETURN COMPLETED FORM TO THE GOVERNMENT ISSUING CONTRACTING OFFICER FOR THE CONTRACT/ PROCURING ACTIVITY NUMBER LISTED IN ITEM 2 OF THIS FORM.		2. PROCURING ACTIVITY NO.	
		3. DODAAC	
4. ORIGINATOR	b. ADDRESS (<i>Street, City, State, Zip Code</i>) Defense Supply Center, Columbus PO box 3990 Columbus, OH 43216-5000	5. CAGE CODE 037Z3	6. NOR NO. 5905-R004-03
a. TYPED NAME (<i>First, Middle Initial, Last</i>)		7. CAGE CODE 037Z3	8. DOCUMENT NO. 87015
9. TITLE OF DOCUMENT RESISTOR NETWORKS, FIXED, FILM, SURFACE MOUNT 28 PIN, LEADLESS CHIP CARRIER		10. REVISION LETTER	
		a. CURRENT D	b. NEW E
		11. ECP NO. No users listed.	
12. CONFIGURATION ITEM (OR SYSTEM) TO WHICH ECP APPLIES All			
13. DESCRIPTION OF REVISION Sheet 1: Revisions ltr column; add "E". Revisions description column; add "Changes in accordance with NOR 5905-R004-03". Revisions date column; add "02-12-17". Revision level block; add "E". Rev status of sheets; for sheet 8, add "E". Sheet 8: Paragraph 6.6, row 3, column 3, delete " 34707 " and substitute " 27851 ", and row 3, column 4, delete " Hy Comp " and substitute " Satcon Electronics ". Revision level block; add "G".			
14. THIS SECTION FOR GOVERNMENT USE ONLY			
a. (<i>X one</i>)	X	(1) Existing document supplemented by the NOR may be used in manufacture.	
		(2) Revised document must be received before manufacturer may incorporate this change.	
		(3) Custodian of master document shall make above revision and furnish revised document.	
b. ACTIVITY AUTHORIZED TO APPROVE CHANGE FOR GOVERNMENT DSCC-VAT		c. TYPED NAME (<i>First, Middle Initial, Last</i>) Kendall A. Cottongim	
d. TITLE CHIEF, ELECTRONIC COMPONENTS TEAM	e. SIGNATURE Kendall A. Cottongim		f. DATE SIGNED (02-12-17)
15a. ACTIVITY ACCOMPLISHING REVISION DSCC-VAT	b. REVISION COMPLETED (<i>Signature</i>) Andrew R. Ernst		c. DATE SIGNED (02-12-17)

1. SCOPE

1.1 Scope. This drawing describes the requirements for a 28 pin, leadless chip carrier, resistor network. These networks are available in hermetically sealed and nonhermetically sealed packages.

1.2 Part or Identifying Number (PIN). The complete PIN is as follows:

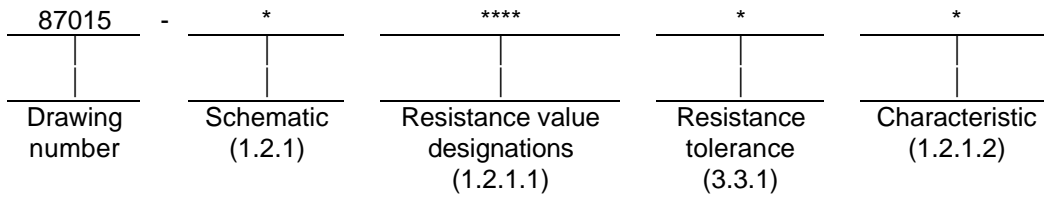

1.2.1 Schematic. The schematic of the resistor network is identified by a single letter in accordance with figure 1.

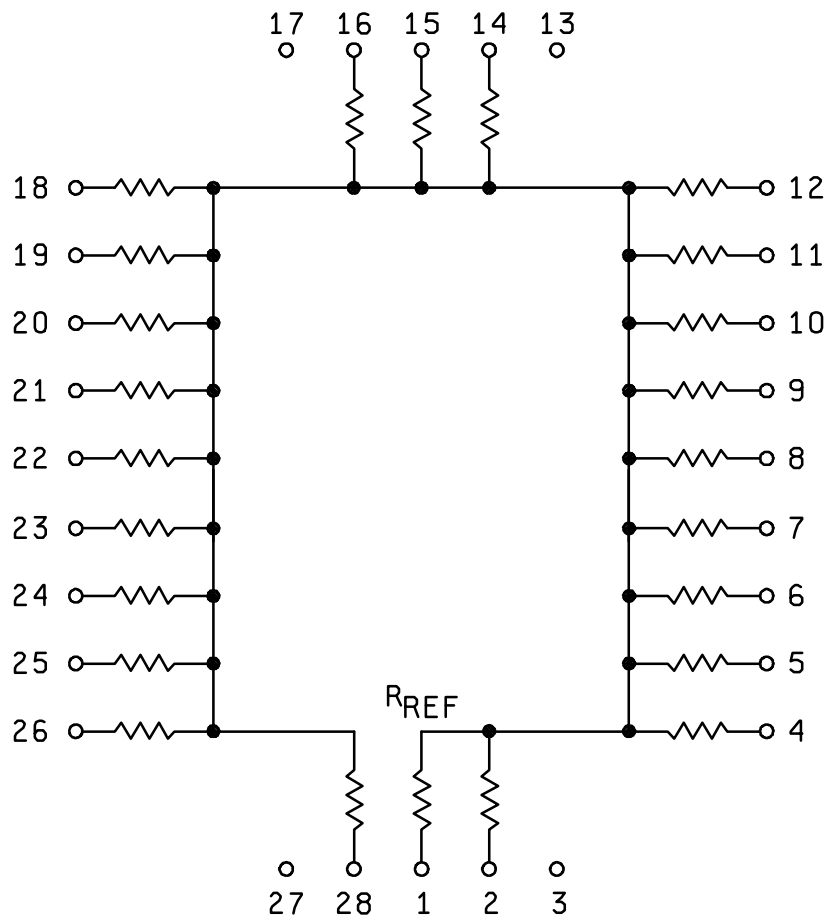

FIGURE 1. Schematics.

DEFENSE SUPPLY CENTER, COLUMBUS COLUMBUS, OHIO	SIZE A	CODE IDENT NO. 14933	DWG NO. 87015
		REV D	PAGE 2

1.2.1.1 Resistance values. The resistance values are in accordance with MIL-PRF-914.

1.2.1.2 Characteristic. Resistor networks are available in characteristics C, H, R, or V in accordance with MIL-PRF-914 (see 3.2).

2. APPLICABLE DOCUMENTS

2.1 Government documents.

2.1.1 Specifications, standards, and handbooks. The following specifications, standards, and handbooks form a part of this document to the extent specified herein. Unless otherwise specified, the issues of these documents are those listed in the issue of the Department of Defense Index of Specifications and Standards (DoDISS) and supplement thereto, cited in the solicitation (see 6.2).

SPECIFICATION

DEPARTMENT OF DEFENSE

MIL-PRF-914 - Resistor Networks, Fixed, Film, Surface Mount, Nonestablished Reliability, and Established Reliability, General Specification for.

STANDARD

DEPARTMENT OF DEFENSE

MIL-STD-790 - Standard Practice for Established Reliability and High Reliability Qualified Products List (QPL) Systems for Electrical, Electronic, and Fiber Optic Parts Specifications.

MIL-STD-1285 - Marking of Electrical and Electronic Parts.

(Unless otherwise indicated, copies of federal and military specifications, standards, and handbooks are available from the Document Automation and Production Service, DPM-DODSSP, Building 4D, 700 Robbins Avenue, Philadelphia, PA 19111-5094.)

2.2 Order of precedence. In the event of a conflict between the text of this document and the references cited herein (except for related associated detail specifications, specification sheets, or MS standards), the text of this document takes precedence. Nothing in this document, however, supersedes applicable laws and regulations unless a specific exemption has been obtained.

3. REQUIREMENTS

3.1 Item requirements. The individual item requirements shall be in accordance with MIL-PRF-914 and as specified herein.

3.2 Interface and physical dimension requirements. Resistors shall meet the interface and physical dimensions as specified in MIL-PRF-914 and herein (see figure 2). Cavity construction using wire bonding techniques shall be supplied only as a characteristic C hermetically sealed resistor network.

3.2.1 Design documentation. The design documentation shall be in accordance with MIL-PRF-914 and, unless otherwise specified in the contract or purchase order, shall be retained by the manufacturer but available for review by the acquiring activity or contractor upon request.

3.2.2 Termination. Termination finish shall be tin-lead or hot solder dip as specified in MIL-PRF-914.

DEFENSE SUPPLY CENTER, COLUMBUS COLUMBUS, OHIO	SIZE A	CODE IDENT NO. 14933	DWG NO. 87015
		REV D	PAGE 3

3.3 Electrical characteristic.

3.3.1 Resistance tolerance. Resistors are available in (B) ± 1 percent, (D) ± 5 percent, (F) ± 1 percent, (G) ± 2 percent, and (J) ± 5 percent tolerances.

3.3.2 Resistor power ratings. The power rating for individual resistors shall be 0.05 watt maximum at 70°C.

3.3.3 Package power rating. The package power rating shall be 1.2 watts maximum at 70°C. For temperatures in excess of 70°C, derate in accordance with MIL-PRF-914.

3.3.4 Power conditioning. Power conditioning shall be in accordance with MIL-PRF-914 at 1.5 times rated power specified for individual resistors (see 3.3.2).

3.3.5 Temperature range. The operating temperature range shall be -55°C to +125°C.

3.3.6 Resistance temperature characteristic. The resistance temperature characteristic shall be in accordance with MIL-PRF-914.

3.3.7 TC tracking. The TC tracking shall be ± 10 ppm/°C.

3.3.8 Resistance range. The resistance range shall be from 10 ohms to 100 kilohms.

3.3.9 Operating voltage. The maximum operating voltage shall be 50 V dc.

3.3.10 Solderability. When resistors are tested as specified in 4.5, there shall be no evidence of electrical or mechanical damage.

3.3.10.1 Failure criteria for leadless packages. The criteria for acceptable solderability during evaluation of the terminations are:

- a. The total surface area of the dipped part of the termination is at least 95 percent covered by a continuous new solder coating.
- b. That pinholes, voids, porosity, nonwetting, or dewetting are not concentrated in one area and do not exceed 5 percent of the total metallized termination area.
- c. That there shall be no solder bridging between any termination area and any other termination area not connected to it by design. In the event that the solder dipping causes bridging, the test shall not be considered a failure provided that a local application of heat (i.e., gas, soldering iron, or redipping) results in solder pullback and no wetting of the dielectric area is indicated by microscope examination at a magnification of between 10x and 20x.

That area of the surface to be tested as specified in 4.5c shall include the total metallized area of both the castellations and the terminal pads. In case of a dispute, the percentage of coverage with pinholes or voids shall be determined by actual measurement of these areas, as compared to the total area.

3.4 Environmental characteristic. The environmental characteristics shall be in accordance with MIL-PRF-914 characteristic C, H, R, or V (see 3.3.6).

3.5 Marking. Marking shall be in accordance with MIL-STD-1285, except the PIN shall be as specified in 1.2, with the manufacturer's CAGE number or trade mark and date code.

DEFENSE SUPPLY CENTER, COLUMBUS COLUMBUS, OHIO	SIZE A	CODE IDENT NO. 14933	DWG NO. 87015
		REV D	PAGE 4

3.6 Recycled, recovered, or environmentally preferable materials. Recycled, recovered, or environmentally preferable materials should be used to the maximum extent possible provided that the material meets or exceeds the operational and maintenance requirements, and promotes economically advantageous life cycle costs.

3.7 Certificate of compliance. A certificate of compliance shall be required from manufacturers requesting to be listed as a suggested source of supply.

3.8 Workmanship. Resistors shall be uniform in quality and free from any defects that will affect life, serviceability, or appearance.

4. VERIFICATION

4.1 Product assurance program. The product assurance program specified in MIL-PRF-914 and maintained in accordance with MIL-STD-790 is not applicable to this document.

4.2 Qualification inspection. Qualification inspection is not applicable to this document.

4.2.1 Failure rate qualification. The failure rate qualification specified in MIL-PRF-914 is not applicable to this document.

4.3 Conformance inspection.

4.3.1 Inspection of product for delivery. Inspection of product for delivery shall consist of group A and group B inspections of MIL-PRF-914.

4.3.2 Certification. The acquiring activity, at its discretion, may accept a certificate of compliance with group B requirements in lieu of performing group B tests (see 6.2d).

4.4 Inspection of packaging. Inspection of packaging shall be in accordance with MIL-PRF-914.

4.5 Solderability. Solderability shall be in accordance with method 208 of MIL-STD-202. The following details shall apply:

- a. Application of flux. Flux type shall be in accordance with MIL-PRF-914. Terminations shall be immersed in the flux, which is at room ambient temperature, to the minimum depth necessary to cover the surface to be tested. The terminations shall be completely immersed by individually dipping each edge with the Y1 axis 30 degrees to 45 degrees from vertical. The terminations to be tested shall be immersed in the flux for a period of 5 seconds to 10 seconds.
- b. Solder dip. The dross and burned flux shall be skimmed from the surface of the molten solder. (NOTE: May not require separate operation in wave or flow pot). The molten solder shall be maintained at a uniform temperature of 245°C ±5°C. The surface of the molten solder shall be skimmed again prior to immersing the terminations in the solder. The part shall be attached to a dipping device and the flux covered terminations immersed, one side at a time, in molten solder to the depth, and in the same manner specified in 4.5a. The immersion and emersion rates shall be 1.000 ±.250 inch per second and dwell time in the solder bath shall be 5.0 seconds ±0.5 second. After the dipping process, the part shall be allowed to cool in air. Residue flux shall be removed from the terminations by rinsing in a suitable solvent. If necessary, a soft cloth or cotton swab moistened with clean 91 percent isopropyl alcohol shall be used to remove all remaining flux.
- c. Examinations of terminations. After each dip coated termination has been thoroughly cleaned of flux, the castellation and pad shall be examined using a magnification between 10x and 20x.

DEFENSE SUPPLY CENTER, COLUMBUS COLUMBUS, OHIO	SIZE A	CODE IDENT NO. 14933	DWG NO. 87015
		REV D	PAGE 5

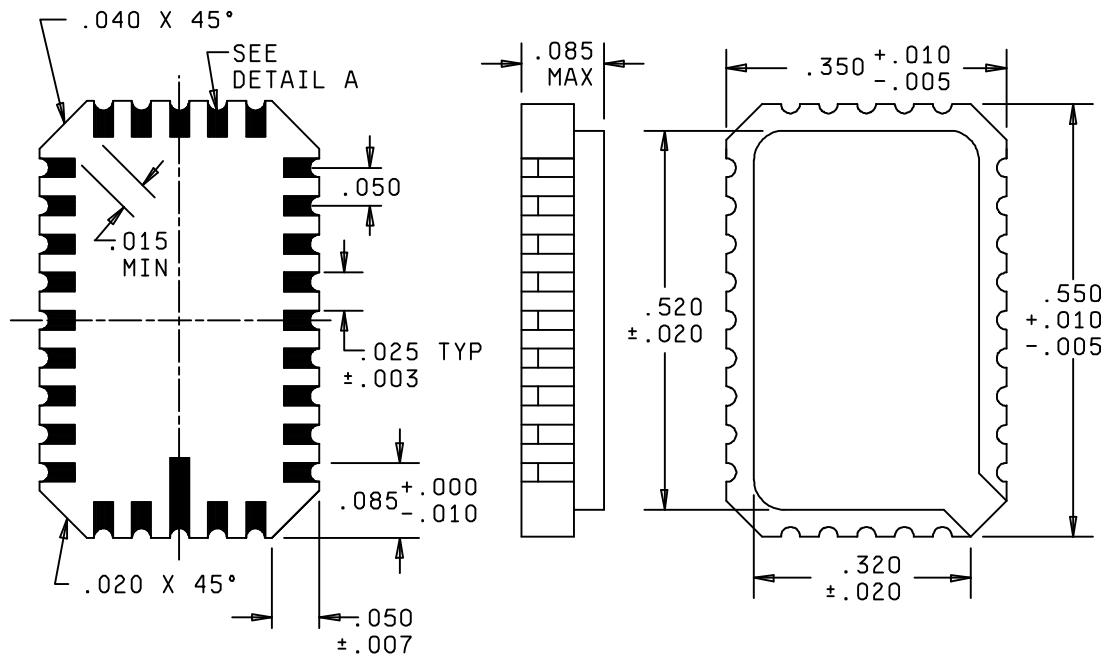

Inches	mm	Inches	mm	Inches	mm
.003	0.08	.020	0.51	.320	8.13
.005	0.13	.025	0.64	.350	8.89
.010	0.25	.040	1.02	.520	13.21
.015	0.38	.050	1.27	.550	13.97
.016	0.41	.085	2.16		

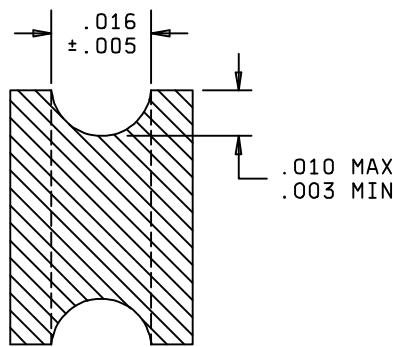

DETAIL A

NOTES:

1. Dimensions are in inches.
2. Metric equivalents are given for general information only.
3. Unless otherwise specified, tolerances are $\pm .008$ (0.20 mm).
4. Adjacent corner pads may be rounded or diagonally cut to meet the $.015$ (0.38 mm) minimum requirement.

FIGURE 2. Leadless chip carrier.

DEFENSE SUPPLY CENTER, COLUMBUS COLUMBUS, OHIO	SIZE	CODE IDENT NO.	DWG NO.
	A	14933	87015
		REV D	PAGE 6

4.6 Visual and mechanical examination. Resistors shall be examined to verify that the materials, design, construction, physical dimensions, marking, and workmanship are in accordance with the applicable requirements of MIL-PRF-914.

5. PACKAGING

5.1 Packaging. For acquisition purposes, the packaging requirements shall be as specified in the contract or order (see 6.2). When actual packaging of materiel is to be performed by DoD personnel, these personnel need to contact the responsible packaging activity to ascertain requisite packaging requirements. Packaging requirements are maintained by the Inventory Control Point's packaging activity within the Military Department or Defense Agency, or within the Military Department's System Command. Packaging data retrieval is available from the managing Military Department's or Defense Agency's automated packaging files, CD-ROM products, or by contacting the responsible packaging activity.

6. NOTES

(This section contains information of a general or explanatory nature that may be helpful, but is not mandatory.)

6.1 Intended use. Resistor networks are used in surface mounting applications where space is a major concern.

6.2 Ordering data. The contract or purchase order should specify the following:

- a. Complete PIN (see 1.2).
- b. Requirements for delivery of one copy of the conformance inspection data or certification of compliance that parts have passed conformance inspection with each shipment of parts by the manufacturer.
- c. Requirements for packaging and packing.
- d. Whether the manufacturer performs the group B tests or provides certification of compliance with group B requirements.

6.3 PIN supersession. PIN's in the original 87015 and revision A have been superseded by a new PIN in revision B that includes a characteristic code to differentiate between hermetically and nonhermetically sealed resistor networks. Table II illustrates a generic PIN substitution:

TABLE II. PIN supersession.

87015 and 87015A	87015B Nonhermetic	87015B Hermetic
87015-*****	87015-*****V 87015-*****H	87015-*****C

6.4 User of record. Coordination of this document, for future revisions, is coordinated only with the suggested sources of supply and the users of record of this document. Requests to be added as a recorded user of this drawing should be in writing to: Defense Supply Center, Columbus (DSCC), DSCC-VAT, Post Office Box 3990, Columbus, OH 43216-5000 or telephone (614) 692-0552 or DSN 850-0552.

DEFENSE SUPPLY CENTER, COLUMBUS COLUMBUS, OHIO	SIZE A	CODE IDENT NO. 14933	DWG NO. 87015
		REV D	PAGE 7

6.5 Suggested sources of supply. A suggested sources of supply are listed herein. Additional suggested sources will be added as they become available. For assistance in the use of this document, contact Defense Supply Center, Columbus (DSCC), DSCC-VAT, Post Office Box 3990, Columbus, OH 43216-5000, or telephone (614) 692-0552 or (DSN) 850-0552.

DSCC drawing PIN 87015-*****	Vendor similar designation or type number <u>1/</u>	Vendor CAGE	Vendor's name and address
Characteristics H, and V; resistance values 10 ohms through 100 kilohms; resistance tolerances B, D, F, G, and J. Schematics A.	79**	57027	IRC, Inc. 4222 S. Staples Street Corpus Christi, TX 78411-2702
Characteristics C; resistance values 50 ohms through 100 kilohms; resistance tolerances B, D, F, G, and J. Schematics A.	102-281	57489	VISHAY Thin Film 2160 Liberty Drive Niagara Falls, NY 14304-3798
Characteristics C; resistance values 100 ohms through 100 kilohms; resistance tolerances B, D, F, G, and J. Schematics A.	HC-153	34707	Hy Comp 165 Cedarhill Street Marlborough, MA 01752-3004

1/ Caution. Do not use this number for item acquisition and marking. Similar vendor type may not satisfy the requirements of this drawing.

DEFENSE SUPPLY CENTER, COLUMBUS COLUMBUS, OHIO	SIZE A	CODE IDENT NO. 14933	DWG NO. 87015
		REV D	PAGE 8