

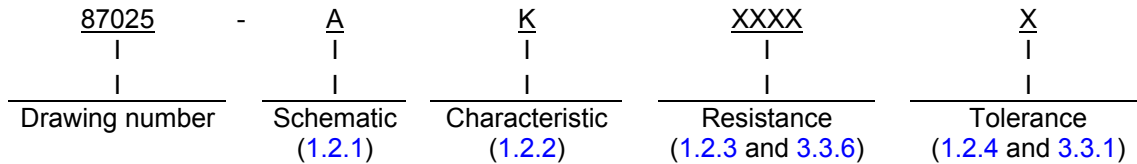

1. SCOPE

1.1 Scope. This drawing describes the requirements for an 8 pin, resistor network.

1.2 Part or Identifying Number (PIN). The complete PIN is as follows:



1.2.1 Schematics. The schematic of the resistor network is identified by a single letter in accordance with the drawings (see figure 1). The resistor element R<sub>REF</sub> is the reference resistor element used in determining the ratio accuracy (when applicable).

1.2.2 Characteristics. The characteristic is identified by a single letter and is in accordance with MIL-PRF-83401.

1.2.3 Resistance value designations. The resistance value designations are in accordance with MIL-PRF-83401. Resistance value designations for the schematic J are as specified in table I.

TABLE I. Standard resistance values.

Resistance designator	R <sub>1</sub> (ohms)	R <sub>2</sub> (ohms)		Resistance Designator	R <sub>1</sub> (ohms)	R <sub>2</sub> (ohms)
A001	82	130		A008	220	330
A002	120	200		A009	330	390
A003	130	210		A010	330	470
A004	160	260		A011	330	680
A005	180	240		A012	1.5 k	3.3 k
A006	180	390		A013	3.0 k	6.2 k
A007	220	270				

1.2.4 Resistance tolerance. For available resistance tolerances and designators, see 3.3.1.

2. APPLICABLE DOCUMENTS

2.1 General. The documents listed in this section are specified in sections 3 and 4 of this specification. This section does not include documents cited in other sections of this specification or recommended for additional information or as examples. While every effort has been made to ensure the completeness of this list, document users are cautioned that they must meet all specified requirements of documents in sections 3 and 4 of this specification, whether or not they are listed.

2.2 Government documents.

2.2.1 Specifications, standards, and handbooks. The following specifications, standards, and handbooks form a part of this document to the extent specified herein. Unless otherwise specified, the issues of these documents are those cited in the solicitation or contract.

DEPARTMENT OF DEFENSE SPECIFICATIONS

**MIL-PRF-83401** - Resistor Networks, Fixed, Film, and Capacitor-Resistor Networks, Ceramic Capacitor and Fixed Film Resistors, General Specification for.

(Copies of these documents are available online at <http://assist.daps.dla.mil/quicksearch/> or <http://assist.daps.dla.mil> or from the Standardization Document Order Desk, 700 Robbins Avenue, Building 4D, Philadelphia, PA 19111-5094.)

<b>DEFENSE ELECTRONIC SUPPLY CENTER</b>	SIZE	CODE IDENT NO.	DWG NO.
<b>DAYTON, OHIO</b>	<b>A</b>	<b>14933</b>	<b>87025</b>
		REV F	PAGE 2

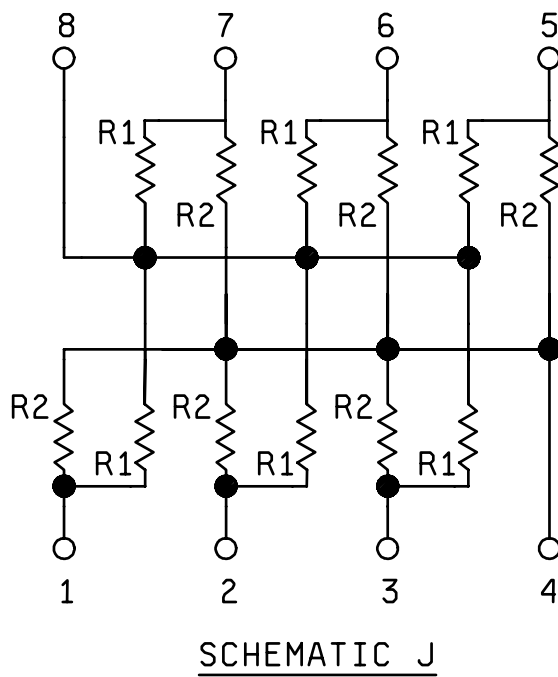
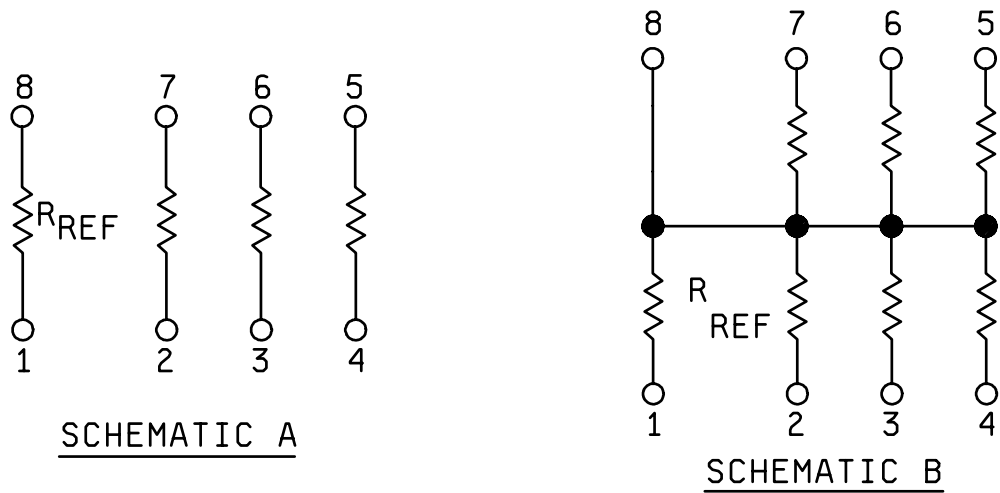

FIGURE 1. Resistor schematics.

<p><b>DEFENSE ELECTRONIC SUPPLY CENTER</b> <b>DAYTON, OHIO</b></p>	<p>SIZE <b>A</b></p>	<p>CODE IDENT NO. <b>14933</b></p>	<p>DWG NO. <b>87025</b></p>
		<p>REV F</p>	<p>PAGE 3</p>

2.3 Order of precedence. In the event of a conflict between the text of this document and the references cited herein, the text of this document takes precedence. Nothing in this document, however, supersedes applicable laws and regulations unless a specific exemption has been obtained.

3. REQUIREMENTS

3.1 Item requirements. The individual item requirements shall be in accordance with MIL-PRF-83401 and as specified herein.

3.2 Interface and physical dimensions. Resistors shall meet the interface and physical dimensions as specified in MIL-PRF-83401 and herein (see figure 1).

3.3 Electrical characteristics.

3.3.1 Resistance tolerance. Resistors are available in B ( $\pm 0.1$  percent), D ( $\pm 0.5$  percent), F ( $\pm 1$  percent), G ( $\pm 2$  percent), and J ( $\pm 5$  percent) tolerances.

3.3.2 Power rating. The power rating per schematics "A", "B", and "J" shall be as follows:

	Element power rating (watts)	Network power rating (watts)
<u>Schematic A</u>		
Characteristics C, R, V, and Y	0.1	0.4
Characteristics H, K, and M	0.2	0.8
<u>Schematic B</u>		
Characteristics C, R, V, and Y	0.05	0.35
Characteristics H, K, and M	0.1	0.7
<u>Schematic J</u>		
Characteristics C and V	0.025	0.3
Characteristics H, K, and M	0.050	0.6

3.3.3 Temperature range. The operating temperature range shall be  $-55^{\circ}\text{C}$  to  $+125^{\circ}\text{C}$ .

3.3.4 Resistance temperature characteristic. The resistance temperature characteristic shall be in accordance with MIL-PRF-83401.

3.3.5 TC tracking. The TC tracking shall be  $\pm 5$  ppm/ $^{\circ}\text{C}$ .

3.3.6 Resistance. The resistance values shall be 10 ohms to 1 megohm.

3.3.7 Operating voltage. The maximum operating voltage shall be 54 V dc for schematic A, 22 V dc for schematic B, and 100 V dc for schematic J.

3.4 Marking. Resistors shall be marked with the PIN assigned herein (see 1.2) and manufacturer's identification code (CAGE or logo). Pin 1 indicator shall be located adjacent to pin 1.

3.5 Recycled, recovered, or environmentally preferable materials. Recycled, recovered, or environmentally preferable materials should be used to the maximum extent possible provided that the materials meet or exceed the operational and maintenance requirements, and promote economically advantageous life cycle costs.

3.6 Certificate of compliance. A certificate of compliance shall be required from manufacturers requesting to be a suggested source of supply.

3.7 Workmanship. Resistors shall be processed in such a manner as to be uniform in quality and free from defects that will affect life, serviceability, or appearance.

<b>DEFENSE ELECTRONIC SUPPLY CENTER</b>	<b>SIZE</b>	<b>CODE IDENT NO.</b>	<b>DWG NO.</b>
<b>DAYTON, OHIO</b>	<b>A</b>	<b>14933</b>	<b>87025</b>
		REV F	PAGE 4

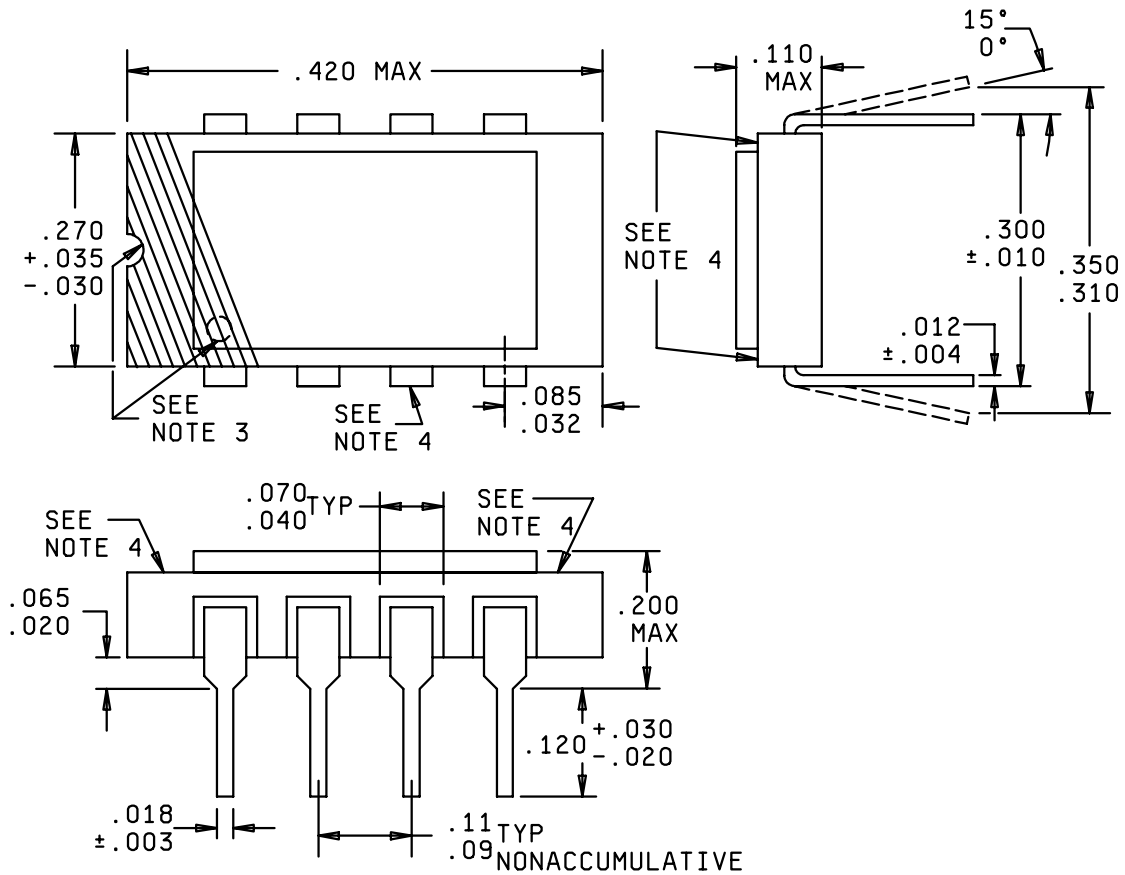

Inches	mm	Inches	mm	Inches	mm	Inches	mm
.003	0.08	.030	0.76	.080	2.03	.270	6.86
.004	0.10	.032	0.81	.085	2.16	.300	7.62
.010	0.25	.035	0.89	.09	2.3	.310	7.87
.012	0.30	.040	1.02	.11	2.8	.350	8.89
.018	0.46	.065	1.65	.120	3.05	.420	10.67
.020	0.51	.070	1.78	.200	5.08		

NOTES:

1. Dimensions are given in inches.
2. Metric equivalents are given for general information only.
3. Pin 1 locator shall be a dot, or a notch in the shaded area.
4. Side brazed configuration optional.

FIGURE 2. Resistor network.

<b>DEFENSE ELECTRONIC SUPPLY CENTER</b> <b>DAYTON, OHIO</b>	SIZE <b>A</b>	CODE IDENT NO. <b>14933</b>	DWG NO. <b>87025</b>
		REV F	PAGE 5

#### 4. VERIFICATION

4.1 Qualification inspection. Qualification inspection in accordance with [MIL-PRF-83401](#) is not applicable to this document.

#### 4.2 Conformance inspection.

4.2.1 Inspection of product for delivery. Inspection of product for delivery shall consist of group A (M level part) and group B inspections of [MIL-PRF-83401](#).

4.2.2 Certification. The acquiring activity, at its discretion, may accept a certificate of compliance with group B requirements in lieu of performing group B tests (see [6.2c](#)).

4.2.3 Power conditioning. The power conditioning shall be performed at rated power.

4.3 Schematic J tests. For the tests on schematic J, the dc resistance measurements, resistance temperature characteristics measurement, and short time overload power application shall be made between each terminal and the application common terminal without compensation for the shunt circuits. The pin to pin dc resistance measurement shall be used directly to determine the acceptability to [section 3](#) requirements.

#### 5. PACKAGING

5.1 Packaging. For acquisition purposes, the packaging requirements shall be as specified in the contract or order (see [6.2](#)). When packaging of materiel is to be performed by DoD or in-house contractor personnel, these personnel need to contact the responsible packaging activity to ascertain packaging requirements. Packaging requirements are maintained by the Inventory Control Point's packaging activities within the Military Service or Defense Agency, or within the military service's system commands. Packaging data retrieval is available from the managing Military Department's or Defense Agency's automated packaging files, CD-ROM products, or by contacting the responsible packaging activity.

#### 6. NOTES

(This section contains information of a general or explanatory nature which may be helpful, but is not mandatory.)

6.1 Intended use. Resistor networks are intended to be used in electronic circuit where miniaturization is required.

6.2 Ordering data. The contract or purchase order should specify the following:

- a. Complete PIN (see [1.2](#)).
- b. Requirements for delivery of one copy of the conformance inspection data or a certificate of compliance that parts have passed conformance inspection with each shipment of parts by the manufacturer.
- c. Whether the manufacturer performs the group B tests or provides certification of compliance with group B requirements.
- d. Requirements for packaging and packing.

6.3 Users of record. Coordination of this document for future revisions is coordinated only with the suggested source of supply and the users of record of this document. Requests to be added as a recorded user of this drawing may be achieved online at [resistor@dla.mil](mailto:resistor@dla.mil) or in writing to: DSCC-VAT, Post Office Box 3990, Columbus, OH 43218-3990 or by telephone (614) 692-0552 or DSN 850-0552.

<b>DEFENSE ELECTRONIC SUPPLY CENTER DAYTON, OHIO</b>	<b>SIZE A</b>	<b>CODE IDENT NO. 14933</b>	<b>DWG NO. 87025</b>
		REV F	PAGE 6

6.4 Suggested source of supply. Suggested source of supply is listed herein. Additional sources will be added as they become available. Assistance in the use of this drawing may be obtained online at [resistor@dla.mil](mailto:resistor@dla.mil) or contact DSCC-VAT, Post Office Box 3990, Columbus, OH 43218-3990 or by telephone (614) 692-0552 or DSN 850-0552.

DSCC drawing PIN	Vendors similar designation or type number <sup>1/</sup>	Vendor CAGE	Vendor's name and address
87025-AXXXXXX characteristics: H, K, M, R, V, Y res. values: 10 to 400k ohms all tolerances 87025-BXXXXXX characteristics: H, K, M, R, V, Y res. values: 10 to 200k ohms all tolerances	1959-XX-XXXXX 1954-XX-XXXXX	57027	International Resistive Company 4222 South Staples Street Corpus Christi, TX 78411-2796
87025-AXXXXXX characteristics: C, R, V res. values: 100 to 499k ohms all tolerances 87025-BXXXXXX characteristics: C, R, V res. values: 100 to 499k ohms all tolerances	103 – 455	57489	Vishay Thin Film 2160 Liberty Drive Niagara Falls, NY 14304
87025-AXXXXXX characteristics: C, R, V res. values: 10 to 33k ohms all tolerances 87025-AYXXXXX res. values: 300 to 33k ohms all tolerances 87025-BXXXXXX characteristics: C, R, V res. values: 25 to 10k ohms all tolerances 87025-BYXXXXX res. values: 300 to 10k ohms all tolerances	1440	18612	Vishay Foil Resistors 63 Lincoln Highway Malvern, PA 19355

<sup>1/</sup> Parts must be purchased to the DSCC PIN to assure that all performance requirements and tests are met.

<b>DEFENSE ELECTRONIC SUPPLY CENTER DAYTON, OHIO</b>	<b>SIZE A</b>	<b>CODE IDENT NO. 14933</b>	<b>DWG NO. 87025</b>
		<b>REV F</b>	<b>PAGE 7</b>