

# TaNFilm® Chip Carrier Resistor Network

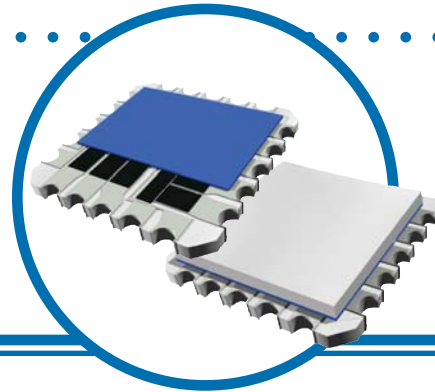

## CCN Series

- Qualified to DESC 87016 and 87017 military specifications
- Gold, Sn/Pb and RoHS compliant terminations available
- Ideal for all reflow soldering techniques
- Meets JEDEC standard for type 'C' package
- Custom schematics readily available
- Absolute TCR to  $\pm 15$  ppm/ $^{\circ}\text{C}$



The IRC TaNFilm® Chip Carrier Network offers higher lead density, increased component count, lower installed resistor cost, better reliability, and is ideal for use with all surface mount solder techniques. In addition, the TaNFilm® leadless CCN provides all the unique qualities of our other TaNFilm® package configurations. Testing has demonstrated performance exceeding MIL-PRF-914 Characteristic H.

Precise state-of-the-art laser trimming provides close tolerances and tight ratios. The TaNFilm® process enables IRC to manufacture custom circuit configurations and multiple resistance values without sacrificing the tightest tolerance and tracking characteristics of precision networks. The Tantalum Nitride resistor material is passivated for environmental protection surpassing military requirements and guaranteeing exceptional ratio stability.

For applications requiring a high degree of reliability, stability, accuracy and low noise, plus the advantages of new resistor configurations, specify the IRC Leadless Chip Carrier Configuration Resistor Network.

## Electrical Data

<b>Resistance Range</b>	10 $\Omega$ to 300K $\Omega$
<b>Absolute Resistance Tolerance</b>	To $\pm 0.1\%$
<b>Ratio Tolerance to R1</b>	to $\pm 0.01\%$
<b>Power Rating @ 70<math>^{\circ}\text{C}</math></b>	0.1 watt/resistor, 1.0 watt/network
<b>Operating Temperature Range</b>	-55 $^{\circ}\text{C}$ to +150 $^{\circ}\text{C}$
<b>Absolute TCR</b>	To $\pm 15$ ppm/ $^{\circ}\text{C}$
<b>TCR Tracking</b>	To $\pm 5$ ppm/ $^{\circ}\text{C}$
<b>Noise</b>	Less than -25 dB
<b>Termination Options (nickel leach barrier)</b>	Gold 60/40 Sn/Pb 100% matte-tin
<b>Substrate Material</b>	99.5% pure alumina substrate
<b>Construction</b>	Epoxy overcoat (78xx) Ceramic lid (79xx)

*Custom circuits and special testing available.*

### General Note

IRC reserves the right to make changes in product specification without notice or liability. All information is subject to IRC's own data and is considered accurate at time of going to print.



# TaNFilm® Chip Carrier Resistor Network



## Manufacturing Capability Data

Circuit	Resistance Range	Available Absolute Tolerances	Available Ratio Tolerances (Ratio to R1)	Best Absolute TCR	Tracking TCR (Track to R1)
<b>Isolated Schematics 7907/7807 7908/7808</b>	10Ω - 24.9Ω	F G J	D F G	±300 ppm/°C	±50 ppm/°C
	25.0Ω - 49.9Ω	F G J	D F G	±100 ppm/°C	±25 ppm/°C
	50Ω - 199Ω	D F G J	B D F G	±50 ppm/°C	±10 ppm/°C
	200Ω - 999Ω	B D F G J	B D F G	±25 ppm/°C	±5 ppm/°C
	1.0K - 50.0K	B D F G J	A B D F G	±25 ppm/°C	±5 ppm/°C
<b>Isolated Schematic 7909/7809</b>	10Ω - 24.9Ω	F G J	D F G	±300 ppm/°C	±50ppm/°C
	25Ω - 74.9Ω	F G J	D F G	±100 ppm/°C	±25 ppm/°C
	75Ω - 379Ω	D F G J	B D F G	±50 ppm/°C	±10 ppm/°C
	380Ω - 999Ω	B D F G J	A B D F G	±25 ppm/°C	±5 ppm/°C
	1.0KΩ - 100KΩ	B D F G J	T Q A B D F G	±25 ppm/°C	±5 ppm/°C
	101KΩ - 250KΩ	B D F G J	A B D F G	±25 ppm/°C	±5 ppm/°C
<b>Bussed Schematic 7900/7800</b>	10Ω - 24.9Ω	F G J	D F G	±300 ppm/°C	±50ppm/°C
	25Ω - 74.9Ω	F G J	D F G	±100 ppm/°C	±25ppm/°C
	75Ω - 149Ω	F G J	B D F G	±50 ppm/°C	±10ppm/°C
	150Ω - 100KΩ	B D F G J	A B D F G	±25 ppm/°C	±5ppm/°C

## Physical Data

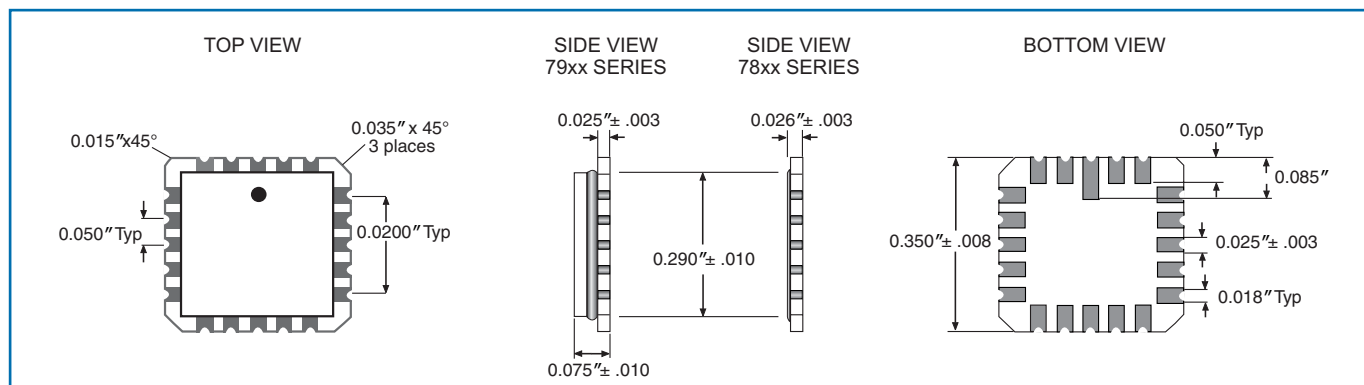

# TaNFilm® Chip Carrier Resistor Network



## Schematic Data

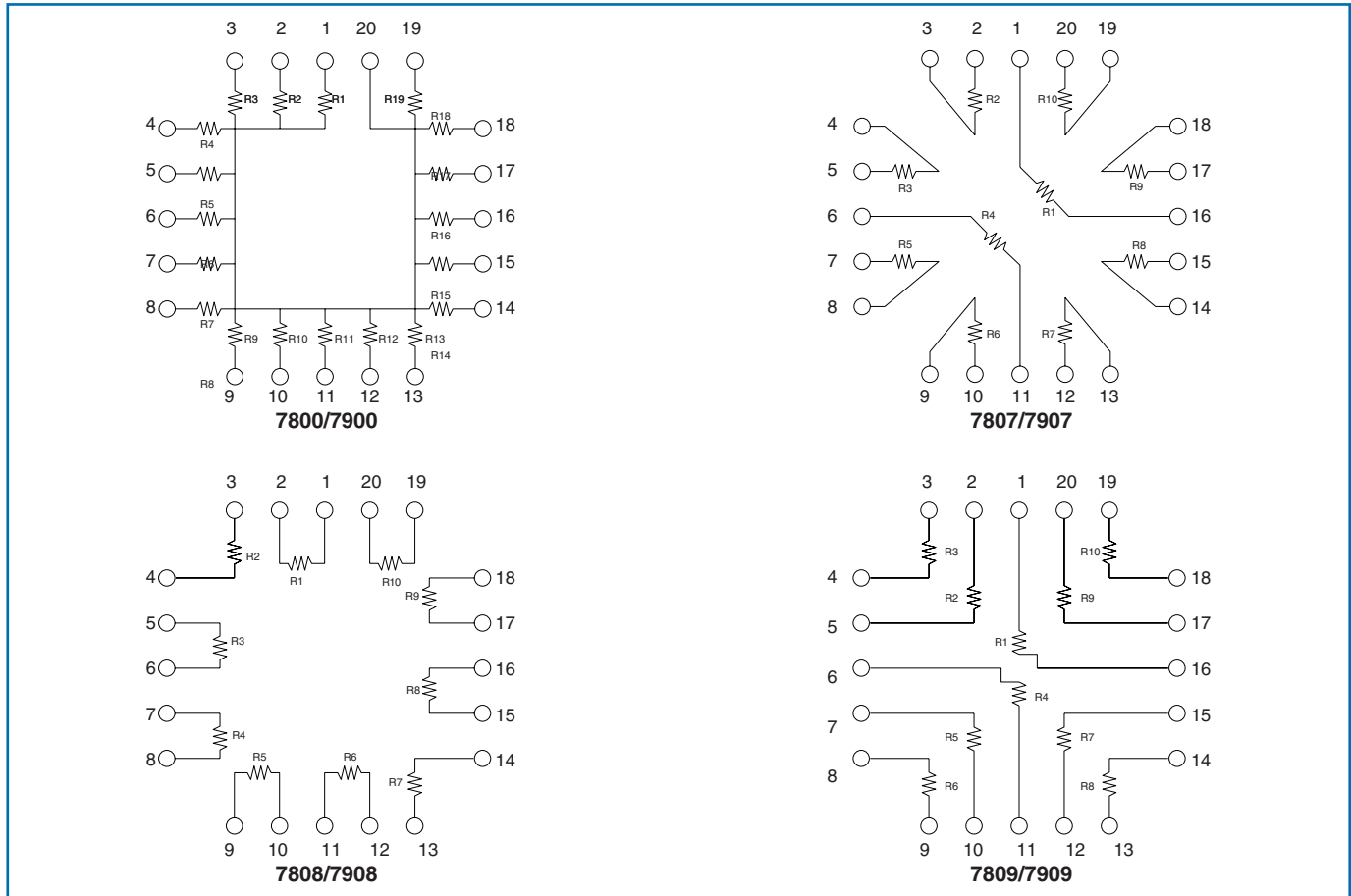

## Environmental Data

Test Per MIL-PRF-914	MIL-PRF-914 Limits ( $\Delta R\%$ )				TaNFilm® Test Data ( $\Delta R\%$ )	
	M	K	H	V	Max	Typical
Thermal Shock and Power Conditioning	0.7	0.7	0.5	0.25	0.1	0.02
Low Temperature Operation	0.5	0.25	0.1	0.1	0.05	0.02
Short Term Overload	0.5	0.25	0.1	0.1	0.05	0.02
Resistance to Bonding Exposure	0.25	0.25	0.25	0.25	0.1	0.02
Steady State Humidity	0.5	0.5	0.5	0.2	0.1	0.03
Moisture Resistance	0.5	0.5	0.4	0.25	0.1	0.03
Shock	0.25	0.25	0.25	0.25	0.1	0.03
Vibration	0.25	0.25	0.25	0.25	0.1	0.03
Life	2.0	0.5	0.5	0.5	0.1	0.03
High Temperature Exposure	1.0	0.5	0.2	0.1	0.1	0.03
Low Temperature Storage	0.5	0.25	0.1	0.1	0.05	0.01

# TaNFilm<sup>®</sup> Chip Carrier Resistor Network



## Power Derating Data

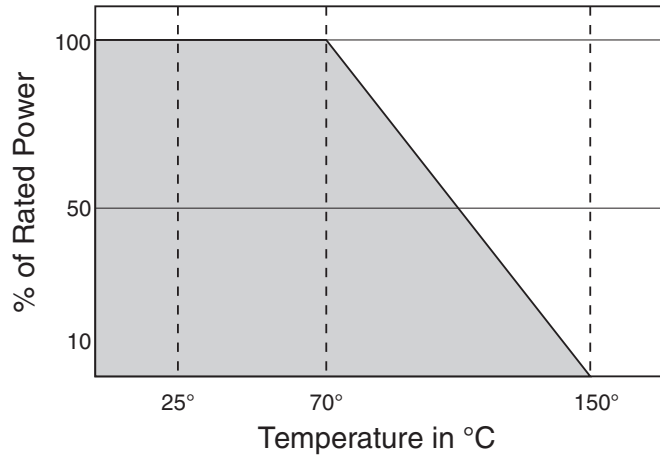

## Ordering Data

Prefix ..... **CCN** - **7900** - **01** - **1001** - **B** - **B**

**Model**  
 7800: 20-pin, 19 resistor schematic, epoxy overcoat construction, 60/40 Sn/Pb solder plate terminations  
 7800LF: 20-pin, 19 resistor schematic, epoxy overcoat construction, 100% matte-tin (Pb-free) terminations

7807: 20-pin, 10 resistor schematic, epoxy overcoat construction, 60/40 Sn/Pb solder plate terminations  
 7807LF: 20-pin, 10 resistor schematic, epoxy overcoat construction, 100% matte-tin (Pb-free) terminations

7808: 20-pin, 10 resistor schematic, epoxy overcoat construction, 60/40 Sn/Pb solder plate terminations  
 7808LF: 20-pin, 10 resistor schematic, epoxy overcoat construction, 100% matte-tin (Pb-free) terminations

7809: 20-pin, 10 resistor schematic, epoxy overcoat construction, 60/40 Sn/Pb solder plate terminations  
 7809LF: 20-pin, 10 resistor schematic, epoxy overcoat construction, 100% matte-tin (Pb-free) terminations

7900: 20-pin, 19 resistor schematic, ceramic lid construction, gold over nickel plate terminations  
 7900SD: 20-pin, 19 resistor schematic, ceramic lid construction, Sn/Pb hot solder dipped terminations  
 7900LF: 20-pin, 19 resistor schematic, ceramic lid construction, 100% matte-tin (Pb-free) terminations

7907: 20-pin, 10 resistor schematic, ceramic lid construction, gold over nickel plate terminations  
 7907SD: 20-pin, 10 resistor schematic, ceramic lid construction, Sn/Pb hot solder dipped terminations  
 7907LF: 20-pin, 10 resistor schematic, ceramic lid construction, 100% matte-tin (Pb-free) terminations

7908: 20-pin, 10 resistor schematic, ceramic lid construction, gold over nickel plate terminations  
 7908SD: 20-pin, 10 resistor schematic, ceramic lid construction, Sn/Pb hot solder dipped terminations  
 7908LF: 20-pin, 10 resistor schematic, ceramic lid construction, 100% matte-tin (Pb-free) terminations

7909: 20-pin, 10 resistor schematic, ceramic lid construction, gold over nickel plate terminations  
 7909SD: 20-pin, 10 resistor schematic, ceramic lid construction, Sn/Pb hot solder dipped terminations  
 7909LF: 20-pin, 10 resistor schematic, ceramic lid construction, 100% matte-tin (Pb-free) terminations

### TCR/Screening Code

Code	Classification	Absolute TCR
00	Commercial Grade	±300ppm/°C
01	Commercial Grade	±100ppm/°C
02	Commercial Grade	±50ppm/°C
03	Commercial Grade	±25ppm/°C
04	MIL-PRF-914M Screened	±300ppm/°C
05	MIL-PRF-914K Screened	±100ppm/°C
06	MIL-PRF-914H Screened	±50ppm/°C
07	MIL-PRF-914H Screened	±25ppm/°C
11	Commercial Grade	±15ppm/°C

### Resistance Code

Standard 4-Digit MIL Resistance Code. Example: 1001 = 1000Ω, 50R0 = 50Ω

### Absolute Tolerance Code

B = ±0.1%; D = ±0.5%; F = ±1%; G = ±2%; J = ±5%

### Ratio Tolerance to R<sub>1</sub>

T = ±0.01%; Q = ±0.02%; A = ±0.05%; B = ±0.1%; D = ±0.5%; F = ±1%; G = ±2%